

1130-2 Pondella Road • Cape Coral, FL 33909

Toll Free: (877) 260-2378

Fax: (239) 772-4414

All HONC concrete docks come standard with the following features:

- Dock Floor is 4,000 lb. concrete reinforced with re-bar in grid configuration and a non-skid finish.
- Retaining Walls are 24"-32" high as site conditions require.
- Retaining Walls are 9" thick, poured solid concrete reinforced with 1/2" re-bar.
- Random brick stucco finish standard on retaining walls. (Smooth stucco finish available upon request.)
- Two (2) mooring cleats on seawall cap.
- Five (5) 3"x6"x12' marine grade timber bumpers anchored with stainless steel bolts.
- One set of steps with optional locations (see below*).
- A 5-step retractable aluminum ladder.

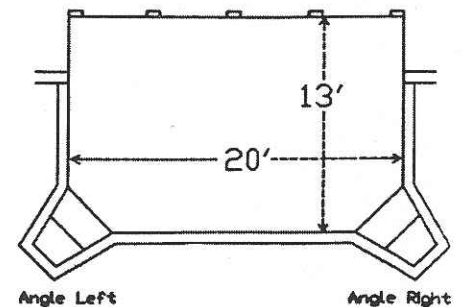
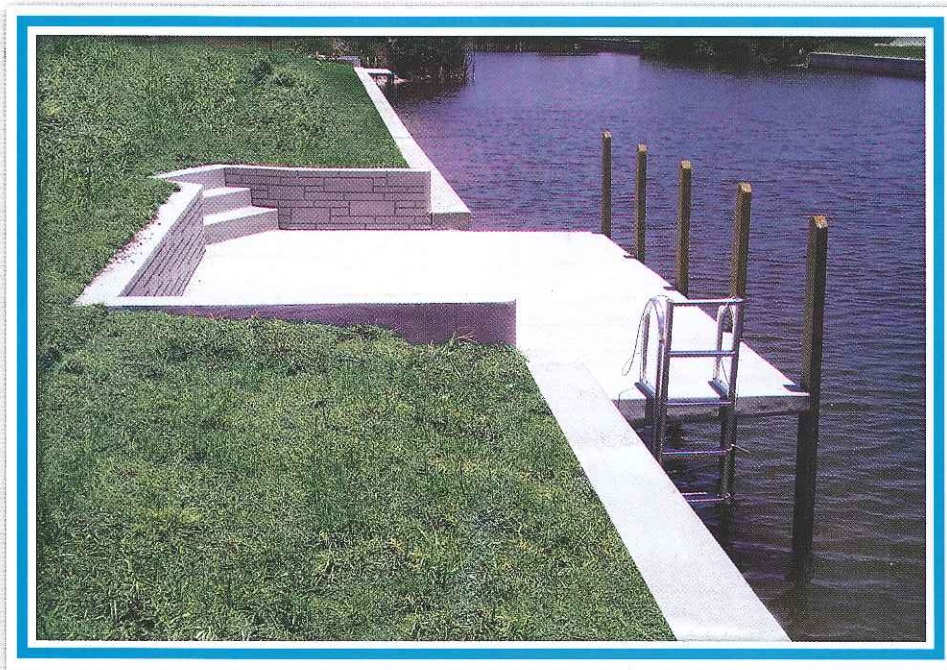
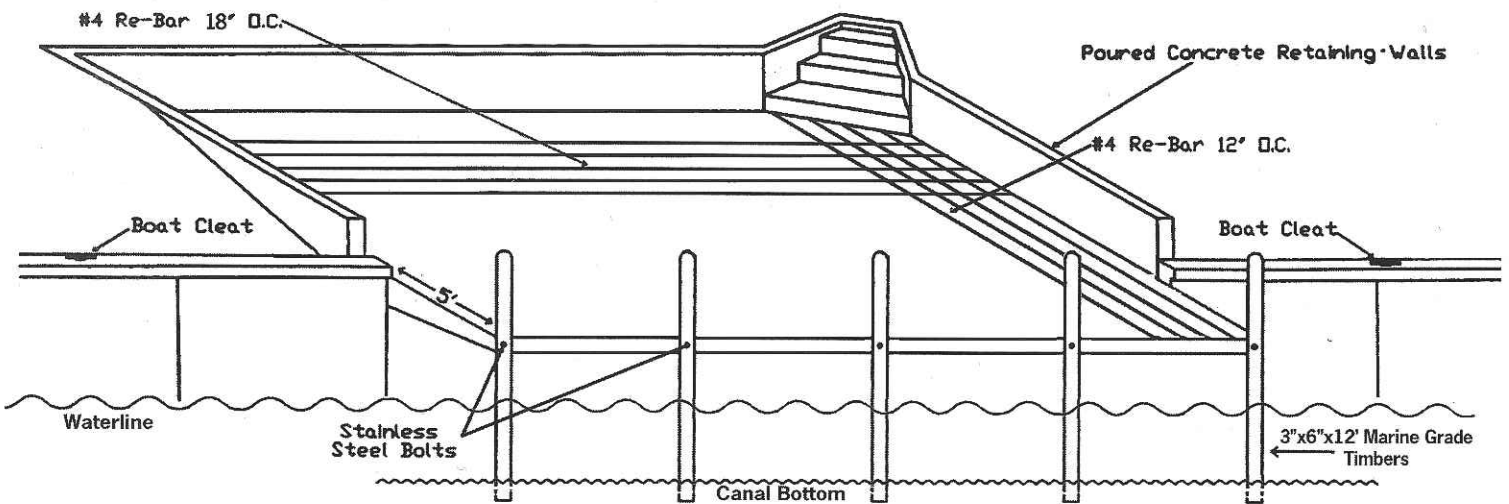

* Standard Step Options
Other Step Configurations
Available Upon Request

NOTE: One set of steps included in base price.

* See Reverse for Concrete Patio